

## **3G STEPPERBIKE OWNER'S MANUAL**



### **CAUTION**

**This Owner's manual is to be read prior to operating your 3G Stepperbike**

This manual contains important safety, performance and maintenance information. Read the manual and all warnings before taking your first ride on your new 3G Stepperbike, and keep the manual handy for future reference.

Unsafe or improper use of the 3G Stepperbike by failing to read and comply with all safety, performance and maintenance requirements and warnings could result in serious injury or death. It is also impossible to predict every situation and condition which will occur while riding. 3G Stepperbike has made no representation about the safe use of the Stepperbike under all conditions. There are risks associated with the use of any Stepperbike which cannot be predicted or avoided and 3G Stepperbike recommends safe cautions riding.

### **Warning**

**Assembly of your 3G Stepperbike by any party other than an authorized 3G Stepperbike dealer voids your warranty. It is strongly recommended to have all post-sale assembly and service work on your Stepperbike performed by a properly trained and equipped dealer.**

**When inspecting your 3G Stepperbike, be certain to tighten all nuts and bolts properly. Under tightening can result in loosening, parts loss, and component damage. Over-tightened nuts and bolts can break. Certain Stepperbike parts have metric hardware Always use the correct tools.**

## **INTRODUCTION**

CONGRATULATIONS on the purchase of your new 3G Stepperbike. This manual is designed to give you the information you need for the safe operation and maintenance of your new Stepperbike. Please read it thoroughly before riding your 3G Stepperbike and record the serial number in this manual in the event your Stepperbike is lost or stolen. You may also want to register your serial number with your local police department. Please retain your sales receipt as proof of purchase and keep with the information below.

MODEL NAME \_\_\_\_\_

SERIAL NUMBER \_\_\_\_\_

COLOR \_\_\_\_\_

DATE OF PURCHASE \_\_\_\_\_

PLACE OF PURCHASE \_\_\_\_\_

# **Contents**

**1. About this Manual**

**2. What it's called**

**3. What kind of 3G Stepperbike is it?**

**4. Fit and Safety**

**A. Fit**

**B. Safety Equipment**

**C. Mechanical Safety Check**

**5. Riding Safely and Responsibly**

**A. The Basics**

**B. Rules and the Road**

**C. Rules and the Trail**

**D. Wet Weather Riding**

**E. Night Riding**

**6. Service and Maintenance**

**7. About your Dealer**

## **1. ABOUT THIS MANUAL**

This manual was written to help you get the most performance, comfort, enjoyment and safety when riding your new 3G Stepperbike. It is important for you to understand your new Stepperbike. By reading this manual before you go out on your first ride, you'll know how to get better performance, comfort, and enjoyment from your new Stepperbike. It is also important that your first ride on your new Stepperbike is taken in a controlled environment, away from cars, obstacles and other cyclists.

### **GENERAL WARNING**

Riding Stepperbike can be a hazardous activity even under the best of circumstances. Proper maintenance of your Stepperbike is your responsibility as it helps reduce the risk of injury. This manual contains many "Warnings" and "Cautions" concerning the consequences of failure to maintain or inspect your 3G Stepperbike. Many of the warnings and cautions say "you may lose control and fall". Because any fall can result in serious injury or even death, we do not repeat the warning of possible injury or death whenever the risk of falling is mentioned.

### **SPECIAL NOTE FOR PARENTS**

It is a tragic fact that many riding accidents involve children. As a parent or guardian, you bear the responsibility for the activities and safety of your minor child. Among these responsibilities are to make sure that the 3G Stepperbike which your child is riding is properly fitted to the child; That it is in good repair and safe operating condition; that you and your child have learned, understand and

obey not only the applicable local motor vehicle, Stepperbike, bicycle and traffic laws, but also the common sense rules of safe and responsible riding Stepperbike. As a parent you should read this manual before letting your child ride the Stepperbike. Please make sure that your child always wears an approved helmet when riding.

## 2. What it's Called

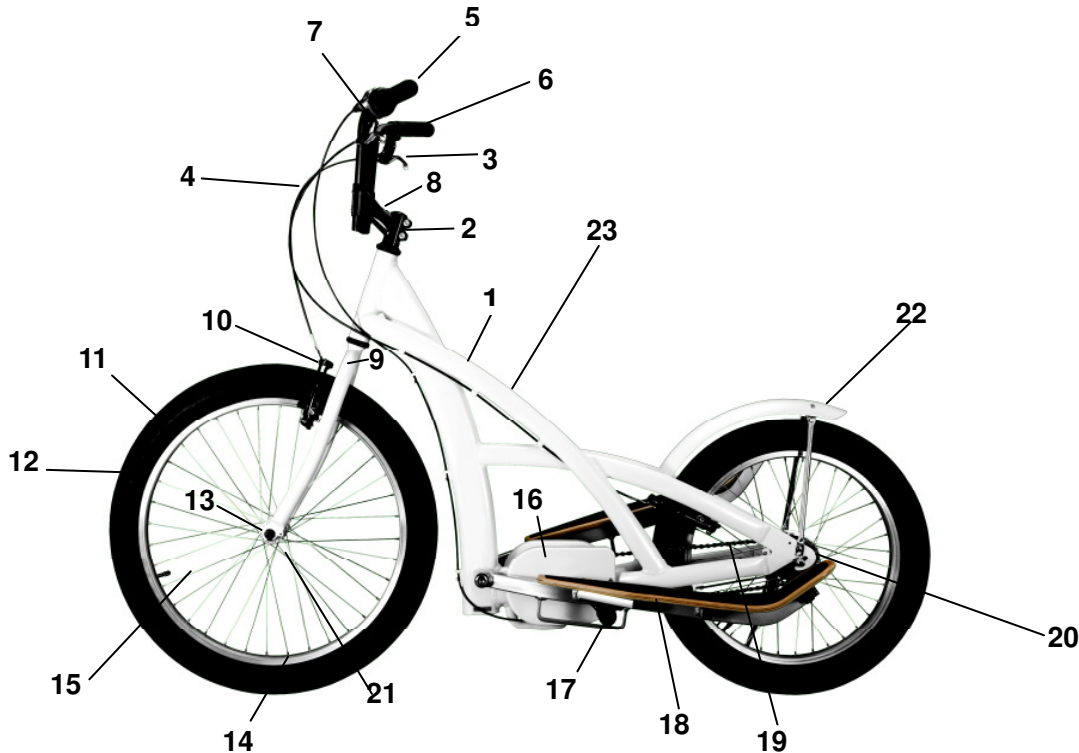

1. frame
2. head parts
3. brake lever
4. shifter cable
5. shifter
6. grip
7. handle bar
8. stem
9. front fork
10. brake
11. tire
12. tube
13. hub
14. rim
15. spokes
16. chain guard
17. pedal
18. deck
19. chain
20. derailleur/Nexus hub
21. quick release
22. fender
23. waterbottle boss  
(waterbottle not included)

### 3. What kind of 3G Stepperbike is it?

Junior



Our 3G Stepperbike can be broadly categorized into three types, according to the different sizes intended to use for different age: Children's Stepperbike, Teenage Stepperbike and Adult Stepperbike. While there is a lot of use overlap in Stepperbike design, each type of our Stepperbike is designed to provide optimum performance, comfort and safety while on the correct size and under specific use conditions. Which type is your 3G Stepperbike?

**Children's Stepperbike** only designed for those children who are age from 8 to 13. This Stepperbike has painted different color intend to the favor of boys and girls. The navy blue Stepperbike we called it Spyder and another fresh yellow was painted is Junior. However, in spite of what color it is, both of them are the same size, specification and design. Their wheels have small outside diameter and the place as well as height of handlebar and deck are suitable for children's height to get the comfort riding posture. The rear brake is Drum-brake which is silent enough to help your riding more enjoyable. It provides you casual, reliable brake performance.



**Teenage Stepperbike** is the best choice of the youth from age 13 to 17. It upgrades from Children's Stepperbike based on function and size. The internal Nexus 3 speed relaxes you to fit different road conditions and provides excellent shifter performance and life-span. The step extent of the deck is suitable for most teenagers' stature as well as drive power fit to the weight of theirs to make riding more easily and fun.



**Adult Stepperbike** is designed for people whose ages are above 17. We categorize this type into Common Version and Senior Version as they are made of different materials for the frame. Gentlemen are fond of the Senior Version, which we call it "Hammer," and ladies prefer the "Work-it." It has an alloy frame with an adjustable handlebar to change the height and angle flexibly according to your like and status of your body that help you to have a more broad and enjoyable riding ... It is also assembled with an 8-speed rear derailleur to fit almost every road condition; the shifter can rotate optionally to adjust the speed when you are riding your Stepperbike.

## 4. Fit and

### Safety



### A. Fit

**Make sure the Stepperbike fits.** A Stepperbike that's too big or too small for the rider is harder to control making it more dangerous and can be uncomfortable.

**Warning: If your 3G Stepperbike does not fit properly, you may lose control and fall. If your new Stepperbike doesn't fit, ask your dealer to exchange it before you ride it.**

The first check for correct size is **standover height**, Standover height is the basic element of Stepperbike fit. To check for safe standover height, straddle the Stepperbike while wearing the kind of shoes in which you'll be riding, both of your hands hold on the grip of the handlebar and if your shoulder is below the height of handlebar. That means the size is larger for you. To ensure your sight-view is not keep off by the parts of handlebar and have an enough seeing space, please chose smaller Stepperbike compare your height.

## Adjusting of handlebar

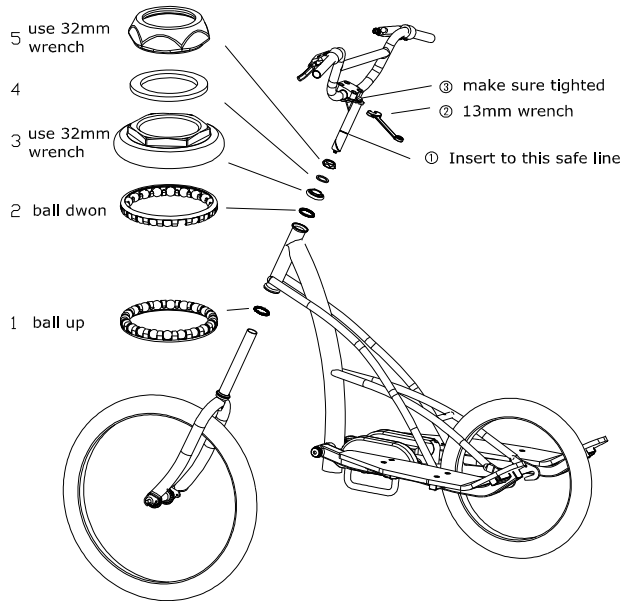

Correct adjusting of handlebar is an important element for you obtained the best performance and comfort, your dealer is very experience to do this and they will tell you where most comfortable position for most people is. Also, if you feel the height and angle lead to uncomfortable for you that you can adjust yourself.

While the handlebar of your 3G Stepperbike insert the head tube through stem, your dealer can raise or lower your handlebars a bit by adjusting stem height. In addition, if you want a higher Stepperbike, the stem must be longer. Please consult your dealer. **Do not attempt to do this yourself, as it requires special knowledge.**

As for most of 3G Stepperbike, you can raise or lower your handlebars a bit by adjusting stem height. Loosen the stem binder bolt by Turing it counterclockwise three or four full turns. If the bolt rises but the stem doesn't, get a piece of

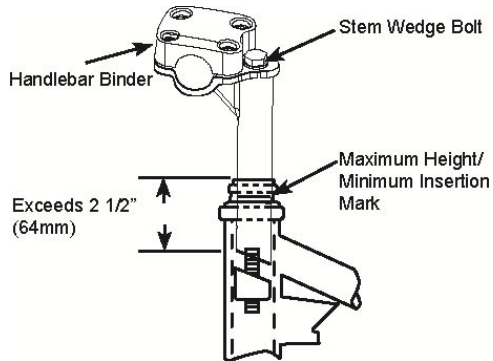

wood or a soft mallet and give the bolt a good whack to release the wedge. Adjust the stem position as desired, align stem with tire, and retighten the binder bolt tight enough so that you cannot twist the stem and handlebars out of alignment. Under no circumstances should the stem be retightened with its “Minimum Insertion” or “Maximum Extension” mark visible. If you are uncertain about the stem mark consult your dealer

If the connection between handlebar and front fork of 3G Stepperbike is hitched stem by handlebar, your dealer can through move the handlebar to realize change of the height and angle of handlebar or you may adjust according to your like.

**CAUTION:** the largest distance by the adjusting of handlebar must reveal 10mm on the bottom-end of

handlebar and make sure the bolts on the steering tube is tighten enough to insure that the steering tube can sustain the whole weight of yourself.

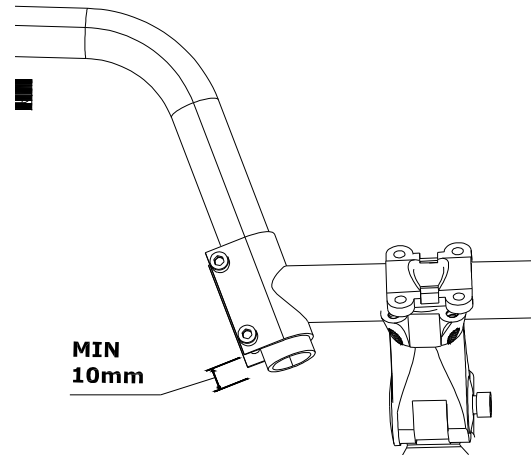
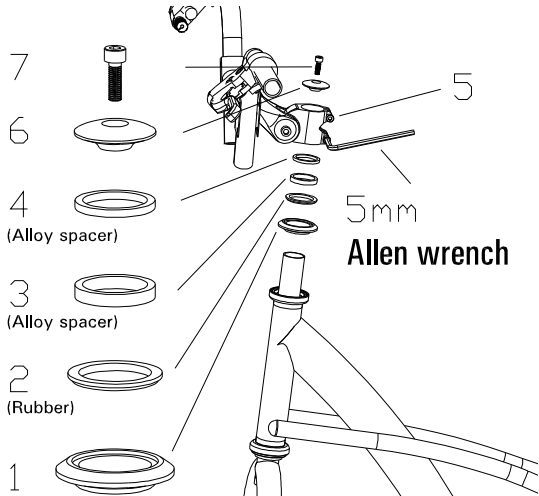

Now check to make sure that the handlebars rotate freely in both directions without the brake cables catching or binding on anything.

**CAUTION:** On some Stepperbike, changing stem height can affect the tension of the front brake cable, locking the front brake or creating sufficient cable slack to make the front brake inoperable. If the front brake shoes move in towards the wheel rim or out away from the wheel rim when you change stem height, take your 3G Stepperbike to your dealer for correct brake adjustment before riding it .

**WARNING:** The minimum Inserting Mark of stem must not be visible above the top of the headset. If the stem is extended beyond the Minimum Inserting Mark, the stem may damage the steering tube of fork or break, which could cause you to lose control and fall.

You can change the angle of the handlebar or bar end extensions by loosening their binder bolt, rotating the bar or extension to the desired angle, re-centering it and retightening the binder bolt tight enough so that the bars or extensions can't move in relation to each other and the stem.

**WARNING:** Failure to properly tighten the stem binder bolt, the handlebar binder bolt or the bar end extension clamping bolts may compromise steering action, which could cause you to lose control and fall. Place the front wheel of the bicycle between your legs and attempt to twist the handlebar/stem assembly. If you can twist the stem in relation to the front wheel, turn the handlebars in relation to the stem, or turn the bar end extensions in relation to the handlebar, tighten the bolts.

**Control position adjustments:** The brake and shifting controls on your bike are positioned where they work best for most people. The angle of the controls and their position on the handlebars can be changed. Ask your dealer to show you how, or to make the adjustments for you.

**Brake reach:** Many 3G Stepperbike have brake levers which can be adjusted for reach. If you have small hands and find it difficult to squeeze the brake levers, your dealer can either adjust the reach or fit shorter reach brake levers.

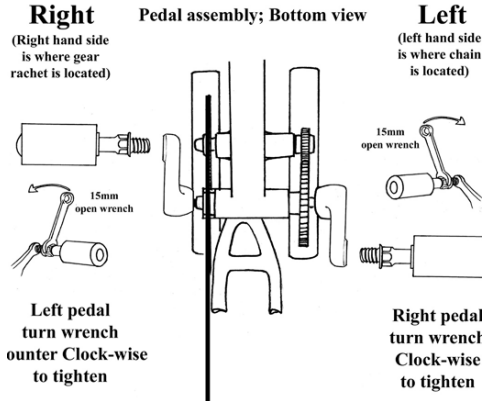

**Assemblage of Cylinder pedals:** you dealer will install the cylinder pedals for you. The cylinder pedals are different on left and right by their different screw direction of thread and on the left hand the pedal (one side without chain) was screwed tight in clock-wise direction as well as The right pedal was screwed in counter clock-wise.

**Do not attempt to disassemble the cylinder pedals and frequent disassemble will damage thread of the pedal to result in injury.**

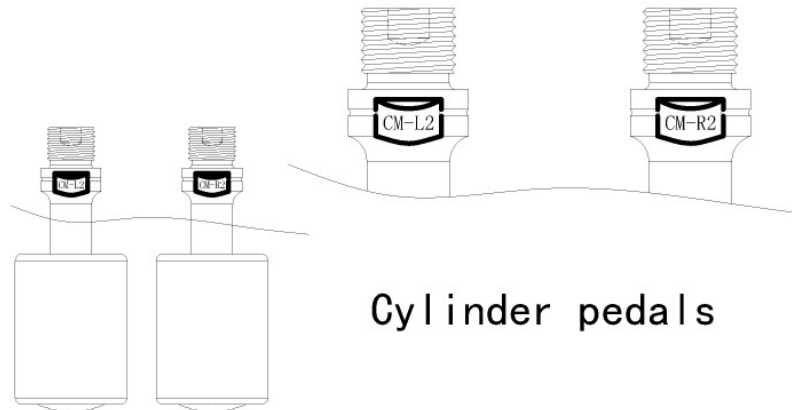

**Deck  
assembly  
bottom  
view**

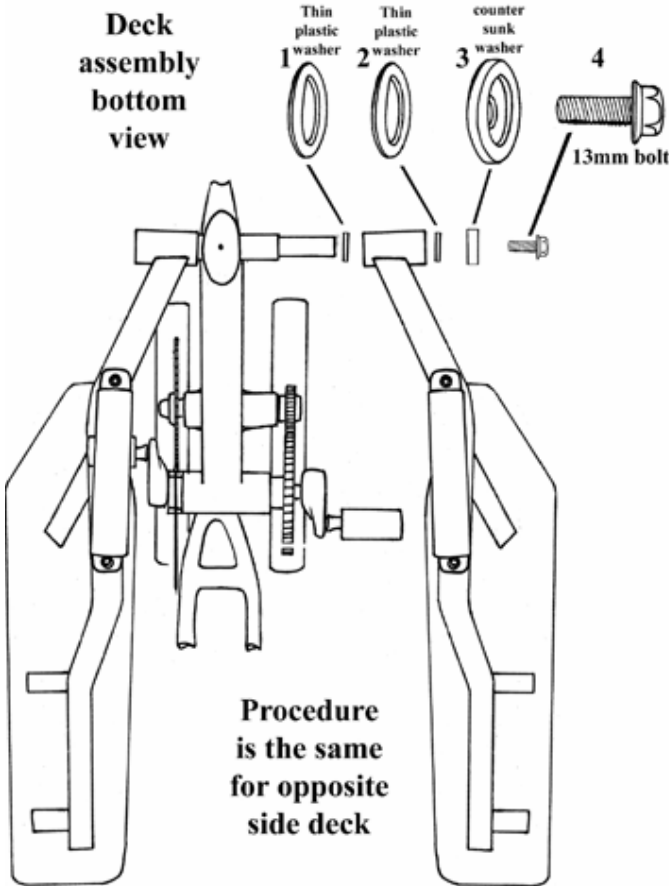

**Procedure  
is the same  
for opposite  
side deck**

**Assemblage of Deck:** your dealer will assemble deck for you. **Do not attempt to disassemble deck, as it requires special knowledge.** If you find that the deck can not rotate freely or have loose, consult your dealer, they will help you to check where the problem is.

Installation of deck: your dealer will install deck for you. Do not attempt to disassemble deck before you are familiar it. When you deck has loosen or can not rotate smoothly, please contact your dealer then they will examine where the problem it is.

**Cautions:**

**There is a railing as protecting device on the bottom of deck. Do not think it is useless and disassemble it. When you are in fast riding, the device can ensure the deck and pedal are connected to keep the good driving performance and reduce the accident.**

**On the surface of deck there is a cloth and its function is increasing the friction between shoes' bottom and surface of deck. Still, we remind riders to wear softer shoes with good friction while they are riding 3G Stepperbike. Especially when they use Stepperbike in a humid circumstance, it is important to prevent slip otherwise they may result in serious injury or death.**

## B. Safety Equipment



**WARNING:** Many states require specific safety devices. It is your responsibility to familiarize yourself with the laws of the states where you ride and to comply with all applicable laws, including properly equipping yourself and your Stepperbike as the law requires.

**Helmet:** While not all States require bicyclists to wear approved protective headgear, common sense dictates that you should wear an ANSI or Snell approved helmet whether the law requires it or not. Most serious Stepperbike injuries involve head injuries which might have been avoided if the rider had worn a helmet. Your dealer has a variety of attractive helmets, and can recommend one to suit your needs. But the “right” helmet is not just a fashion statement. It must fit correctly, be worn correctly and be properly secured to do its real job. Ask your dealer to help you with the fit and adjustment of your helmet.

**WARNING: Always wear a helmet when riding your 3G Stepperbike. Always keep the chin strap securely buckled. Failure to wear an approved helmet may result in serious injury or death.**

**Reflectors:** Reflectors are important safety devices which are designed as an integral part of your Stepperbike.

Federal regulations require every Stepperbike to be equipped with front, rear, wheel and pedal reflectors. The size, performance and location of each reflector are specified by the U.S. Consumer Products Safety Commission. The reflectors are designed to pick up and reflect street lights and car lights in a way that helps you to be seen and recognized as a moving rider.



**CAUTION: Check reflectors and their mounting brackets regularly to make sure that they are clean, straight, unbroken and securely mounted. Have your dealer replace damaged reflectors and straighten or tighten any that are bent or loose.**



**WARNING:** Do not remove the reflectors or reflector mounting brackets from your 3G Stepperbike. They are an integral part of the Stepperbike's safety system. Removing the reflectors may reduce your visibility to others using the roadway. Being struck by other vehicles often results in serious injury or death. Remember: reflectors are not a substitute for lights. Always equip your Stepperbike with all state and locally mandated lights.

**Lights:** If you ride your 3G Stepperbike after dusk, your Stepperbike must be equipped with lights so that you can see the road and avoid road hazards; and so that others can see you. Vehicle laws treat Stepperbike like any other vehicles. That means you must have a white front and a red rear light operating if you are riding after dusk. Your Stepperbike dealer can recommend a battery or generator powered lighting system appropriate to your needs.



**WARNING:** Reflectors are not a substitute for proper lights.

**It is your responsibility to equip your Stepperbike with all state and locally mandated lights. Riding at dawn, at dusk, at night or at other times of poor visibility without a Stepperbike lighting system which meets local and state laws and without reflectors is dangerous and may result in serious injury or death. Front and rear lights are not standard equipment on this Stepperbike if you intend to ride at dawn, dusk evening hours, at night or at any other time in which there are poor visibility conditions you must have front and rear lights and reflector adequate for those riding conditions lights and reflector may not be adequate under all conditions to insure that a motorist will see you.**

**Eye protection:** Any kind of riding, but particularly off-road riding, involves airborne dirt, dust and bugs, so it's a good idea always to ride with protective eyewear—tinted when the sun is bright, clear when it's not, Most Stepperbike shops carry protective eyewear, some with interchangeable lens systems.



**CAUTIONS:** To avoid injury you should always wear suitable protective clothing, including pants and shin guards.

## **C. Mechanical Safety Check**

Mechanical Safety Check

Here is a simple, sixty-second mechanical safety check which you should get in the habit of making every time you're about to get on a 3G Stepperbike.

**Nuts, bolts & straps:** Lift the front wheel off the ground by two or three inches, then let it bounce on the ground. Anything sound, feel or look loose? Do a quick visual and tactile inspection of the whole Stepperbike. any loose parts or accessories ? If so, secure them, If you're not sure, ask someone with experience to check.

**Tires & Wheels:** Tires correctly inflated? Check by putting one hand on the saddle, one on the intersection of the handlebar and stem, then bouncing your weight on the Stepperbike while looking at tire deflection. Compare what you see with how it looks when you know the tires are correctly inflated; and adjust if necessary.

Tires in good shape? Spin each wheel slowly and look for cuts in the tread and sidewall. Replace damaged tire before riding the

Stepperbike.

Wheels true? Spin each wheel and check for brake clearance and side-to-side wobble. If a wheel wobbles side to side or hits the brake pads, take the Stepperbike to a qualified Stepperbike shop to have the wheel trued.



**CAUTION:** Wheels must be true for the brakes to work effectively. Wheel truing is a skill which requires special tools and experience. Do not attempt to true a wheel unless you have the knowledge and tools needed to do the job correctly.

**Brakes:** Squeeze the brake lever. Are the brake quick releases closed? The straddle cable securely engaged? Are the brake shoes contacting the wheel rim within an inch of brake lever movement? Can you apply full braking force at the levers without having them touch the handlebar? If not, your brakes need adjustment. Do not ride the Stepperbike until the brakes are properly adjusted.



**WARNING:** Riding with improperly adjusted brakes or worn

**brake shoes is dangerous and can result in serious injury or death. Do not attempt to adjust your brakes, chain or wheels while the Stepperbike is in motion.**

**WARNING: Loose or damaged handlebar grips or extensions can cause you to lose control and fall. Unplugged handlebars or extensions can act like a cockle cutter on your body, and can cause serious injury in an otherwise minor accident.**

**WARNING: Do not engage in any activity which exceeds your riding ability and skill. Practice new riding skills in a safe controlled environment.**

**WARNING: Keep hands, fingers and feet away from all moving parts while the Stepperbike is in motion, including the chain, chain ring, tire, wheels, brakes and brakes cables.**

**OK: now buckle on your helmet and enjoy your ride.**

**NOTE: Like any sport, Stepperbike rider involves risk of serious injury death and damage. By choosing to ride a**

**5.**

**Riding Safely**

**Stepperbike, you assume the responsibility for the risk. Not the people who sold you the Stepperbike. Not the people who made it. Not the people who distribute it. Not the people who manage or maintain the roads or trails, where you ride on. So you need to know—and to practice—the rules of safe and responsible riding.**

#### **A. The Basis**

1. **Always** do the Mechanical Safety (Section 4.C) before you get on a 3G Stepperbike.

2. **Always** wear a cycling helmet which meets the latest Snell or ANSI standard.

3. Be careful to keep body parts and other objects away from the sharp teeth of chain rings; the moving chain; the turning pedals and cranks; and the spinning wheels of your Stepperbike .

4. **Always** wear shoes that will stay on your feet and will grip the pedals. Never ride barefoot or wearing sandals.

5. Be thoroughly familiar with the controls of your 3G Stepperbike.

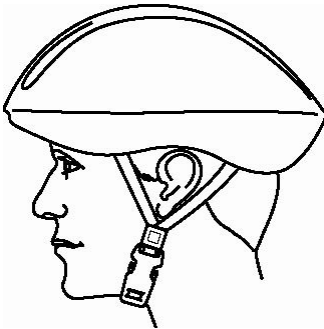

6. Wear bright, visible clothing that is not so loose that it can catch on moving parts of the Stepperbike or be snagged by objects at the side of the road or trail.

Wear clothing safe and suitable for the type of riding you will be engaged in.

7. Don't jump with your Stepperbike. Jumping a Stepperbike can be fun; but it puts incredible stress on everything from your spokes to your pedals. Riders who insist on jumping their Stepperbike risk serious damage, to their Stepperbike which could result in serious personal injury or death to themselves.

## **B. Rules of the Road**

1. Learn the local bicycle and Stepperbike laws and regulations (if have). Many communities may have special regulations about licensing of Stepperbike, riding on sidewalk, laws regulating Stepperbike or bike path and trail use, and so on. Many states have helmet laws, child carrier laws and special traffic laws (for example. Stepperbike laws). It's your responsibility to know and obey the laws.

2. You are sharing the road or the path with other—motorists,

pedestrians and other cyclist (when you are riding outdoor).Respect their rights, and be tolerant if they infringe on yours.

3. Ride defensively. Assume that the people with whom you are sharing the road are so absorbed with what they are doing and where they are going that they are oblivious to you.

4.Look ahead of where you're going, and be ready to avoid:

- \* Vehicles slowing or turning in front of you, entering the road or your lane ahead of you, or coming up behind you.

- \*Parked car doors opening in front of you.

- \* Pedestrians stepping out in front of you.

- \* Children playing near the road.

- \* Pot holes, sewer grating, railroad tracks, expansion joints, road or sidewalk construction, debris and other obstructions that could cause you to swerve into traffic, catch your wheel or otherwise cause you to lose control and have an accident.

- \* The many other hazards and distractions which can occur on a bicycle ride.

5. Ride in designated bike or Stepperbike lanes, on designated bike or Stepperbike paths or on the right side of the road, in the

same direction as car traffic and as close to the edge of the road as possible.

6. Stop at stop signs and traffic lights; slow down and look both ways at street intersections. Remember that a Stepperbike always loses in a collision with a motor vehicle, so be prepared to yield even if you have the right of way.
7. Use hand signals for turning and stopping. Learn the local vehicle code for the correct signals.
8. Never carry anything which obstructs your vision or your complete control of the Stepperbike, or which could become entangled in the moving parts of the Stepperbike.
9. Never hitch a ride by holding on to another vehicle.
10. Don't do stunts, wheelies or jumps. They can cause you injury and damage your Stepperbike.
11. Don't weave through traffic or make any moves that may surprise people with whom you are sharing the road.
12. Observe and yield the right of way.
13. Never ride your Stepperbike while under the influence of alcohol or drugs.
14. If possible, avoid riding in bad weather, when visibility is obscured, at dusk or in the dark, or when extremely tired. Each

of these conditions increases the risk of accident.

### **C. Rules of the Trail**

1. Be prepared. If something goes wrong while you're riding off-road, the closest help may be miles away..
2. Don't ride alone in remote areas. Even when riding with others, make sure that someone knows where you're going and when you expect to be back.
3. Surface hazards make off-road riding much more difficult and therefore more dangerous than riding on paved roads. Start slowly and build up your skills on easier terrain before tackling the more difficult.
4. Learn and obey the local laws regulating where and how you can ride off-road and respect private property. Don't ride where you are not welcome or where you are not allowed.
5. You are sharing the trail with others – hikers, equestrians, other cyclists. Respect their rights, and be tolerant if they inconvenience you.
6. Yield right of way to pedestrians and animals. Ride in a way that does not frighten or endanger them, and stay far enough away so that their unexpected moves don't endanger you.
7. Observe all traffic regulations. Obey red and green lights.

one-way streets, stop signs, etc.

8. Never hitch on other vehicles, do not “Stunt” ride or race in traffic. Don’t weave in and out of traffic or swerve from side to side.
9. Never carry other riders or packages that obstruct vision or proper control of the bicycle.
10. You may be riding in sensitive habitat, so stay on the designated trail. Don’t contribute to erosion by riding in mud or with unnecessary sliding. Don’t disturb wildlife or livestock; and don’t disturb the ecosystem by cutting your own trail through vegetation or streams.
11. It is your responsibility to minimize your impact on the environment. Ride accordingly. Leave things as you found them; and always take out everything you brought in.

#### **D. Wet Weather Riding**

WARNING: Wet weather impairs traction, braking and visibility, both for the Stepperbike rider and for other vehicles sharing the road. The risk of accident is dramatically increased in wet conditions. Under wet conditions, the stopping power of your brakes (as well as the brakes of other vehicles sharing the road) is dramatically reduced and your tires don’t grip nearly as well. This

makes it harder to control speed and easier to lose control. To make sure that you can slow down and stop safely in wet conditions, ride more slowly and apply your brakes earlier and more gradually than you would under normal, dry conditions.

### **E. Night Riding**

Riding a Stepperbike at night is many times more dangerous than riding during the day. Therefore; children should never ride at dusk or at night. Adults should not ride at dusk or at night unless it is absolutely necessary.

**WARNING: Riding at dusk, after dark or at times of poor visibility without a Stepperbike lighting system which meets local and state laws and without reflectors is dangerous and can result in serious injury or death.**

Even if you have excellent night vision, many of the people with whom you're sharing the road don't. A Stepperbike rider is very difficult for motorists and pedestrians to see at dusk, at night, or at other times of poor visibility. If you must ride under these conditions, check and be sure you comply with all local laws about night riding;

follow the Rules of the Road and of the Trail even more carefully, and you must take the following additional precautions:

Before riding at dusk or at night, take the following steps to make yourself more visible:

- 1 Make sure that your Stepperbike is equipped with correctly positioned and securely mounted reflectors.
- 1 Purchase and install an adequate battery of generator powered head and tail light.
- 1 Wear light colored, reflective clothing and accessories, such as a reflective vest, reflective arm and leg bands, reflective stripes on your helmet, flashing lights... any reflective device or light source that moves will help you get the attention of approaching motorists, pedestrians and other traffic.
- 1 Make sure your clothing or anything you may be carrying on the Stepperbike does not obstruct a reflector or light.

While riding at dusk or at night:

- 1 Ride slowly.
- 1 Avoid areas of heavy traffic, dark areas, and roads with speed limit over 35 mph.
- 1 Avoid road hazards.
- 1 If possible, ride on routes already familiar to you.

- 1 Have a light and reflector system even if not required by State or Local Law.

## **6. Service and Maintenance**

NOTE: Stepperbike is the products by more and more advance technology and creation. It is can be played as fitting room equipment as well as fun. This on-going evolution makes it impossible for this manual to provide all the information required to properly repair and/or maintain your Stepperbike. In order to help minimize the chances of and accident and possible injury, it is critical that you have any repair or maintenance which is not specifically described in this manual performed by your dealer.

Equally important is that your individual maintenance requirements will be determined by everything from your riding style to geographic location. Consult your dealer for help in determining your maintenance requirements.

How much of your 3G Stepperbike's service and maintenance you can do yourself depends on your level of skill and experience, and on whether you have the special tools required.

**WARNING:** Many Stepperbike service and repair tasks require special knowledge and tools. Do not begin any adjustments or service on your 3G Stepperbike if you have the slightest doubt about your ability to properly complete them. Improper adjustment or service may result in damage to the Stepperbike or in an accident which can cause serious injury or death.

If you want to learn to do major service and repair work on your 3G Stepperbike, you have three options:

1. Ask your dealer whether copies of the manufacturer's installation and service instructions for the components on your Stepperbike are available.
2. Ask your dealer to recommend a book on Stepperbike repair.
3. Ask your dealer about the availability of Stepperbike repair course in your area.

Regardless of which option you select, we recommend that you ask your dealer to check the quality of your work the first time you work on something and before you ride the Stepperbike, just to make sure that you did everything correctly. Since that will require the time of mechanic, there may be a modest charge for this service.

## **7. About your Dealer**

Your dealer is here to help you get the 3G Stepperbike and accessories which are most appropriate for the kind of riding that you intend to do; and to help you maintain your equipment so that you can get the maximum enjoyment from it. Your Stepperbike shop's staff has the knowledge, tools and experience to give you reliable advice and competent service. Your dealer carries the products of a variety of manufacturers so that you can have the choices which best meet your needs and your budget.

But your dealer's staff can't make decisions for you; nor can they assume responsibility for your lack of knowledge, experience, skill or common sense. They can explain to you how something works, or what part or accessory will meet your special needs, but they can't know your questions or your needs unless you tell them.

If you have a problem with your 3G Stepperbike or your riding, talk to your dealer. Make sure that the dealer understands your problem or question, and make sure that you really understand the answers. When in doubt use caution.

# 3G BIKES

---

the art of motion

[www.3gbikes.eu](http://www.3gbikes.eu)